

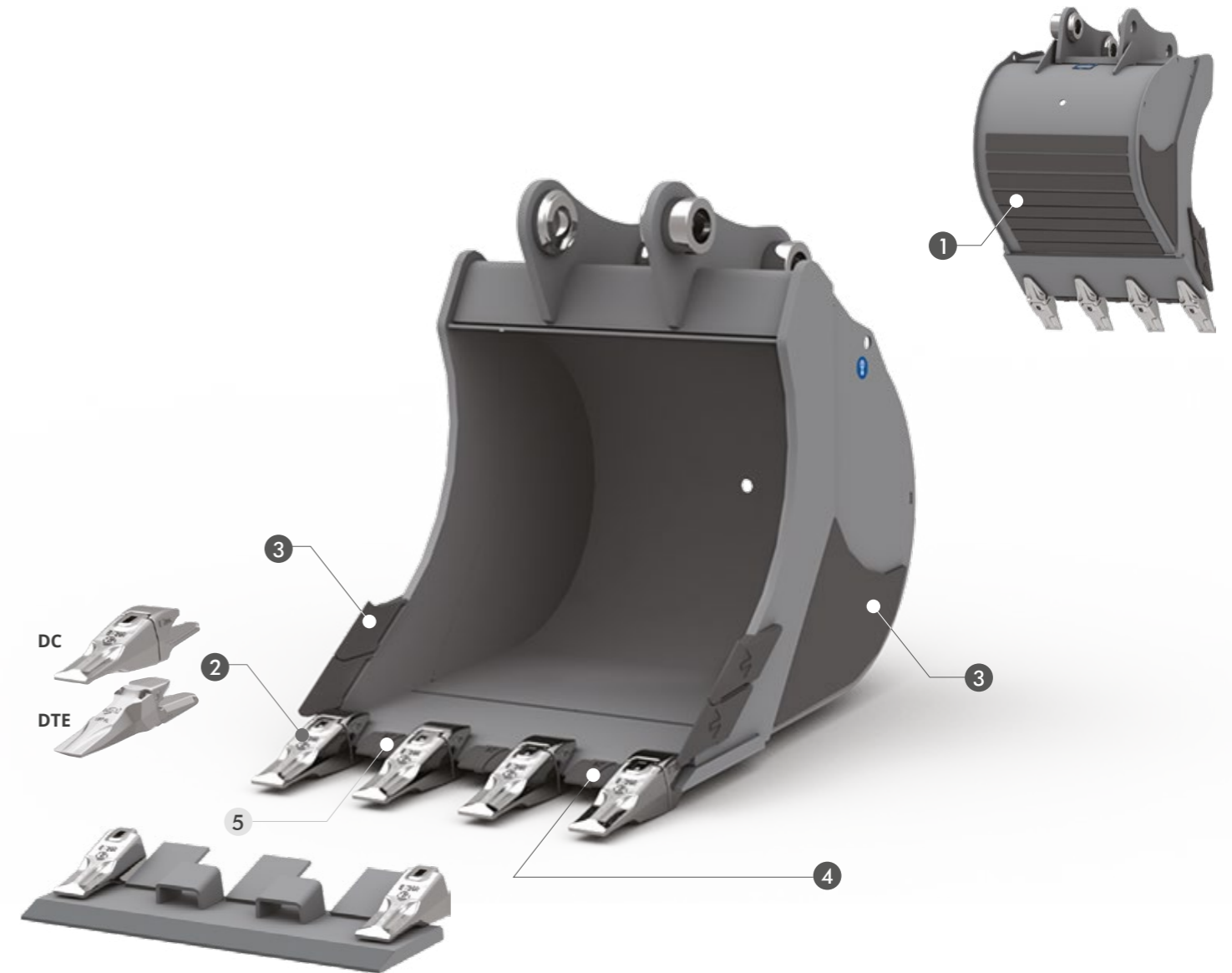

OPTIMALES, KRAFTSPARENDES EINDRINGVERHALTEN AUF VORWIEGEND FELSIGEN BÖDEN. ROBUST UND EXTREM VERSCHLEISSBESTÄNDIG DANK LÖFFELKÖRPER- UND SEITENVERSTÄRKUNGEN, SEITENSCHNEIDEN UND EINE SCHNEIDKANTEN-SCHUTZVERKLEIDUNG AUS HB400-STAHL.



ADAPTERS



## STANDARD TECHNISCHE DATEN

- 1 VERSTÄRKTER VERSCHLEISS-SCHUTZ HB400**  
DIE WAAGERECHTEN VERSTÄRKUNGEN BIETEN OPTIMALEN VERSCHLEISSSCHUTZ UND SCHÜTZEN DIE STRUKTUR.
- 2 ZÄHNE DC ZÄHNE DTE**
- 3 MESSER-SEITENSCHNEIDEN HB400 SEITENVERSTÄRKUNGEN**  
DIE SEITENSCHNEIDEN SIND AUS HB 400. SIE SCHNEIDEN DAS MATERIAL BEIM ERDAUSHUB UND DIENEN ZUSÄTZLICH ALS VERSCHLEISSSCHUTZ.
- 4 VERSTÄRKTES MESSER**  
VERSCHLEISSSTEILE AUS HB400 BIS ZU 10 TONNEN.  
SCHNEIDE AUS HB400 FÜR LÖFFEL ÜBER 10 TONNEN.

## ZUBEHÖR

- 5 AUFSTECKMESSER**  
DAS AUFSTECKMESSER EIGNET SICH FÜR DIE FERTIGSTELLUNG / EINEBNUNG, DA ES KEINE SPUREN DER ZÄHNE HINTERLÄSST. WEITERHIN ERHÖHT ES DAS LADEVOLUMEN.

MOD.	MIDI EXCAVATOR											
	SCR36	SCR38	SCR45	SCR53	SCR62	SCR67	SCR73	SCR80	SCR85	SCR92 HD	SCR100 HD	SCR110 HD
TONS	1,2 - 1,8	1,2 - 1,8	1,8 - 2,5	2,5 - 4,0	4,0 - 5,0	5,0 - 7,5	7,5 - 10,0	10,0 - 12,0	12,0 - 14,0	12,0 - 14,0	14,0 - 16,0	16,0 - 18,0

## SCR36 MASCHINENGEWICHT 1,2 - 1,8

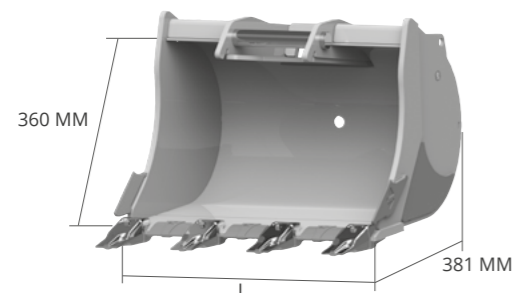
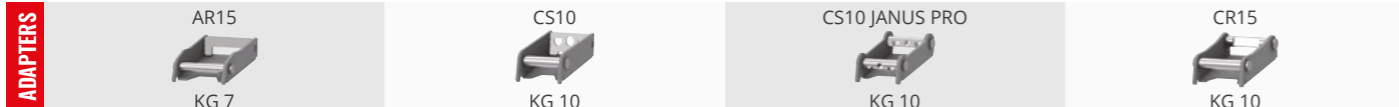

### ZUBEHÖR

5  
AUFSTECKMESSER

L MM	GEWICHT KG*	KAP. SAE L	ZÄHNE N°	ADAPTERS
200	17	15	2	AR - CS
				CR
				CS JANUS PRO
250	19	20	DF2 DC3 DE3	AR - CS
				CR
				CS JANUS PRO
300	22	25	3	AR - CS
				CR
				CS JANUS PRO
350	24	31	3	AR - CS
				CR
				CS JANUS PRO
400	28	37	3	AR - CS
				CR
				CS JANUS PRO
450	31	43	3	AR - CS
				CR
				CS JANUS PRO
500	35	49	4	AR - CS
				CR
				CS JANUS PRO
600	39	61	4	AR - CS
				CR
				CS JANUS PRO
700	44	74	5	AR - CS
				CR
				CS JANUS PRO

\* Gewicht des Löffel ohne Anbauteile und Zähne

## SCR38 MASCHINENGEWICHT 1,2 - 1,8

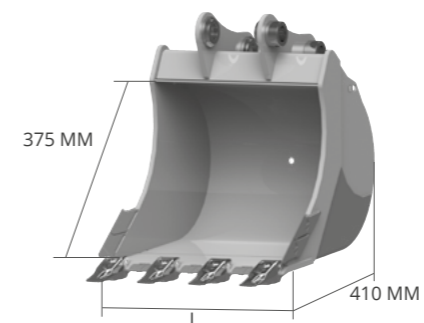

### ZUBEHÖR

5  
AUFSTECKMESSER

L MM	GEWICHT KG*	KAP. SAE L	ZÄHNE N°	ADAPTERS
200	17	15	2	AF - AR - CS
				CR - S - CM
				CW - CS JANUS PRO
250	19	20	DF2 DC3 DE3	AF - AR - CS
				CR - S - CM
				CW - CS JANUS PRO
300	22	25	3	AF - AR - CS
				CR - S - CM
				CW - CS JANUS PRO
350	24	31	3	AF - AR - CS
				CR - S - CM
				CW - CS JANUS PRO
400	28	37	3	AF - AR - CS
				CR - S - CM
				CW - CS JANUS PRO
450	31	43	3	AF - AR - CS
				CR - S - CM
				CW - CS JANUS PRO
500	35	49	4	AF - AR - CS
				CR - S - CM
				CW - CS JANUS PRO
600	39	61	4	AF - AR - CS
				CR - S - CM
				CW - CS JANUS PRO
700	44	74	5	AF - AR - CS
				CR - S - CM
				CW - CS JANUS PRO

\* Gewicht des Löffel ohne Anbauteile und Zähne

## SCR45 MASCHINENGEWICHT 1,8 - 2,5

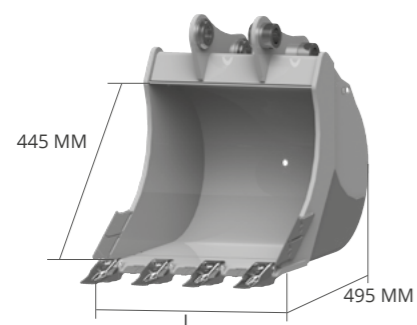
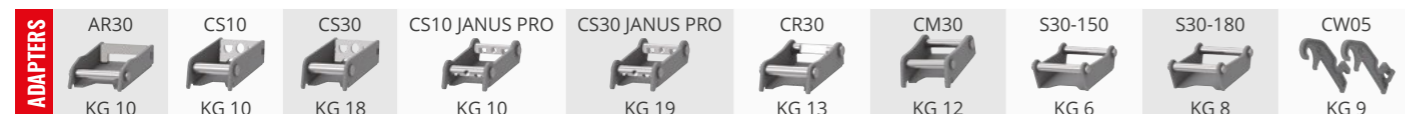

L MM	GEWICHT KG*	KAP. SAE L	ZÄHNE N°	ADAPTERS
250	26	25	DF2 DC3 DE3	AF - AR - CS
				CR - S - CM
				CW - CS JANUS PRO
300	29	33	3	AF - AR - CS
				CR - S - CM
				CW - CS JANUS PRO
350	32	40	3	AF - AR - CS
				CR - S - CM
				CW - CS JANUS PRO
400	36	48	3	AF - AR - CS
				CR - S - CM
				CW - CS JANUS PRO
450	39	56	3	AF - AR - CS
				CR - S - CM
				CW - CS JANUS PRO
500	43	65	4	AF - AR - CS
				CR - S - CM
				CW - CS JANUS PRO
600	50	82	4	AF - AR - CS
				CR - S - CM
				CW - CS JANUS PRO
700	56	100	5	AF - AR - CS
				CR - S - CM
				CW - CS JANUS PRO
800	65	117	5	AF - AR - CS
				CR - S - CM
				CW - CS JANUS PRO

\* Gewicht des Löffel ohne Anbauteile und Zähne

## SCR53 MASCHINENGEWICHT 2,5 - 4,0

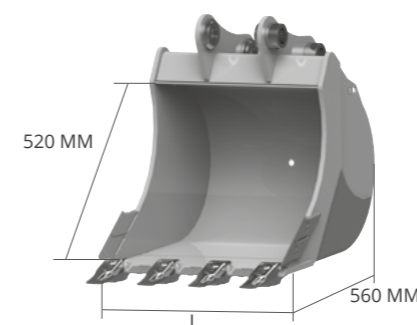

L MM	GEWICHT KG*	KAP. SAE L	ZÄHNE N°	ADAPTERS
250	37	32	2	AF - AR - CS
				CR - S - CM
				CW - CS JANUS PRO
300	40	41	3	AF - AR - CS
				CR - S - CM
				CW - CS JANUS PRO
350	46	51	3	AF - AR - CS
				CR - S - CM
				CW - CS JANUS PRO
400	51	61	3	AF - AR - CS
				CR - S - CM
				CW - CS JANUS PRO
450	55	72	3	AF - AR - CS
				CR - S - CM
				CW - CS JANUS PRO
500	59	82	4	AF - AR - CS
				CR - S - CM
				CW - CS JANUS PRO
600	67	105	4	AF - AR - CS
				CR - S - CM
				CW - CS JANUS PRO
700	76	127	5	AF - AR - CS
				CR - S - CM
				CW - CS JANUS PRO
800	85	152	5	AF - AR - CS
				CR - S - CM
				CW - CS JANUS PRO
900	93	175	5	AF - AR - CS
				CR - S - CM
				CW - CS JANUS PRO

\* Gewicht des Löffel ohne Anbauteile und Zähne

### ZUBEHÖR

5  
AUFSTECKMESSER

### ZUBEHÖR

5  
AUFSTECKMESSER

## SCR62 MASCHINENGEWICHT 4,0 - 5,0

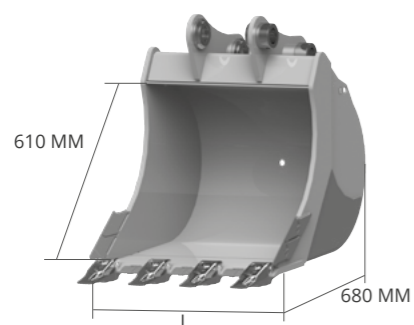

L MM	GEWICHT KG*	KAP. SAE L	ZÄHNE N°	ADAPTERS
250	57	45	2	AF - AR - CS
				CR - S - CM
				CW - CS JANUS PRO
300	63	58	3	AF - AR - CS
				CR - S - CM
				CW - CS JANUS PRO
350	68	71	3	AF - AR - CS
				CR - S - CM
				CW - CS JANUS PRO
400	74	85	3	AF - AR - CS
				CR - S - CM
				CW - CS JANUS PRO
450	79	100	3	AF - AR - CS
				CR - S - CM
				CW - CS JANUS PRO
500	86	115	4	AF - AR - CS
				CR - S - CM
				CW - CS JANUS PRO
600	97	147	4	AF - AR - CS
				CR - S - CM
				CW - CS JANUS PRO
700	109	180	5	AF - AR - CS
				CR - S - CM
				CW - CS JANUS PRO
800	121	213	5	AF - AR - CS
				CR - S - CM
				CW - CS JANUS PRO
900	133	248	6	AF - AR - CS
				CR - S - CM
				CW - CS JANUS PRO
1000	145	282	6	AF - AR - CS
				CR - S - CM
				CW - CS JANUS PRO

\* Gewicht des Löffel ohne Anbauteile und Zähne

## SCR67 MASCHINENGEWICHT 5,0 - 7,5

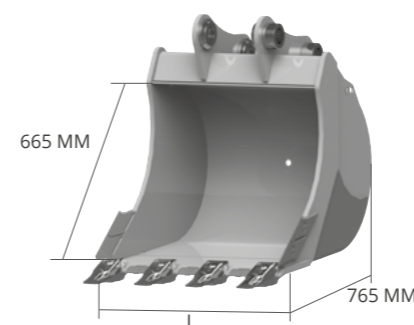

L MM	GEWICHT KG*	KAP. SAE L	ZÄHNE N°	ADAPTERS
300	83	68	3	AF - AR - CS
				CR - S - CM
				CW - CS JANUS PRO
350	92	84	3	AF - AR - CS
				CR - S - CM
				CW - CS JANUS PRO
400	101	101	3	AF - AR - CS
				CR - S - CM
				CW - CS JANUS PRO
450	109	118	3	AF - AR - CS
				CR - S - CM
				CW - CS JANUS PRO
500	117	137	4	AF - AR - CS
				CR - S - CM
				CW - CS JANUS PRO
600	134	174	4	AF - AR - CS
				CR - S - CM
				CW - CS JANUS PRO
700	150	214	5	AF - AR - CS
				CR - S - CM
				CW - CS JANUS PRO
800	167	254	5	AF - AR - CS
				CR - S - CM
				CW - CS JANUS PRO
900	183	295	6	AF - AR - CS
				CR - S - CM
				CW - CS JANUS PRO
1000	199	338	6	AF - AR - CS
				CR - S - CM
				CW - CS JANUS PRO

\* Gewicht des Löffel ohne Anbauteile und Zähne

### ZUBEHÖR

5  
AUFSTECKMESSER

### ZUBEHÖR

5  
AUFSTECKMESSER

## SCR73 MASCHINENGEWICHT 7,5 - 10,0

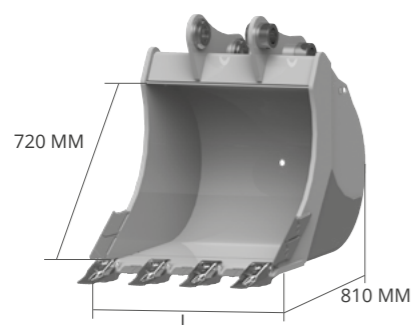

L MM	GEWICHT KG*	KAP. SAE L	ZÄHNE N°	ADAPTERS
300	95	76	2	AF - CS
				CR - S - CM
				CW - CS JANUS PRO
350	103	94	3	AF - CS
				CR - S - CM
				CW - CS JANUS PRO
400	110	113	3	AF - CS
				CR - S - CM
				CW - CS JANUS PRO
450	120	133	3	AF - CS
				CR - S - CM
				CW - CS JANUS PRO
500	130	153	3	AF - CS
				CR - S - CM
				CW - CS JANUS PRO
600	148	196	4	AF - CS
				CR - S - CM
				CW - CS JANUS PRO
700	166	240	4	AF - CS
				CR - S - CM
				CW - CS JANUS PRO
800	184	286	5	AF - CS
				CR - S - CM
				CW - CS JANUS PRO
900	202	333	5	AF - CS
				CR - S - CM
				CW - CS JANUS PRO
1000	220	379	5	AF - CS
				CR - S - CM
				CW - CS JANUS PRO
1100	238	430	5	AF - CS
				CR - S - CM
				CW - CS JANUS PRO

\* Gewicht des Löffel ohne Anbauteile und Zähne

## SCR80 SC80 MASCHINENGEWICHT 10,0 - 12,0

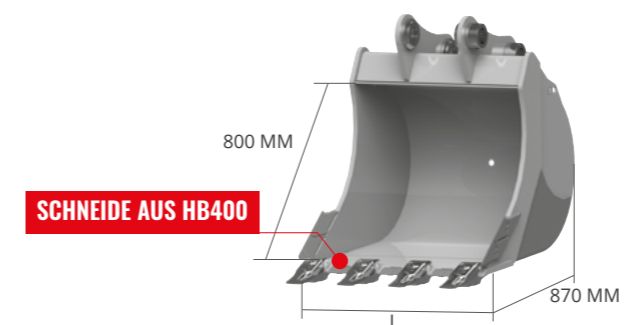

L MM	GEWICHT KG*	KAP. SAE L	ZÄHNE N°	ADAPTERS
300	119	86	2	AF - CS
				CR - S - CM - CS JANUS PRO
				CW
350	128	107	3	AF - CS
				CR - S - CM - CS JANUS PRO
				CW
400	141	129	3	AF - CS
				CR - S - CM - CS JANUS PRO
				CW
450	151	151	3	AF - CS
				CR - S - CM - CS JANUS PRO
				CW
500	162	174	3	AF - CS
				CR - S - CM - CS JANUS PRO
				CW
600	182	222	4	AF - CS
				CR - S - CM - CS JANUS PRO
				CW
700	203	273	4	AF - CS
				CR - S - CM - CS JANUS PRO
				CW
800	222	325	5	AF - CS
				CR - S - CM - CS JANUS PRO
				CW
900	242	379	5	AF - CS
				CR - S - CM - CS JANUS PRO
				CW
1000	261	433	5	AF - CS
				CR - S - CM - CS JANUS PRO
				CW
1100	282	486	5	AF - CS
				CR - S - CM - CS JANUS PRO
				CW
1200	303	546	6	AF - CS
				CR - S - CM - CS JANUS PRO
				CW
1300	323	602	6	AF - CS
				CR - S - CM - CS JANUS PRO
				CW

\* Gewicht des Löffel ohne Anbauteile und Zähne

### ZUBEHÖR

5  
AUFSTECKMESSER

### ZUBEHÖR

5  
AUFSTECKMESSER

## SCR85 MIDI MASCHINENGEWICHT 12,0 - 14,0

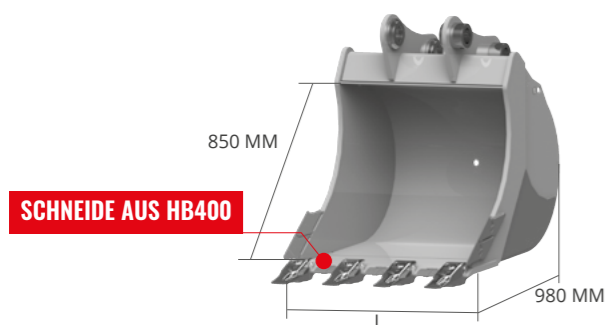

L MM	GEWICHT KG*	KAP. SAE L	ZÄHNE N°	ADAPTERS
400	197	171	3	AF - S - CM
				CS - CW
				CS JANUS PRO
500	220	235	3	AF - S - CM
				CS - CW
				CS JANUS PRO
600	243	300	4	AF - S - CM
				CS - CW
				CS JANUS PRO
700	266	368	4	AF - S - CM
				CS - CW
				CS JANUS PRO
800	289	438	5	AF - S - CM
				CS - CW
				CS JANUS PRO
900	312	510	5	AF - S - CM
				CS - CW
				CS JANUS PRO
1000	336	584	5	AF - S - CM
				CS - CW
				CS JANUS PRO
1100	360	657	5	AF - S - CM
				CS - CW
				CS JANUS PRO
1200	384	730	6	AF - S - CM
				CS - CW
				CS JANUS PRO
1300	408	810	6	AF - S - CM
				CS - CW
				CS JANUS PRO

\* Gewicht des Löffel ohne Anbauteile und Zähne

## SCR92 HD EXCAVATOR MASCHINENGEWICHT 12,0 - 14,0

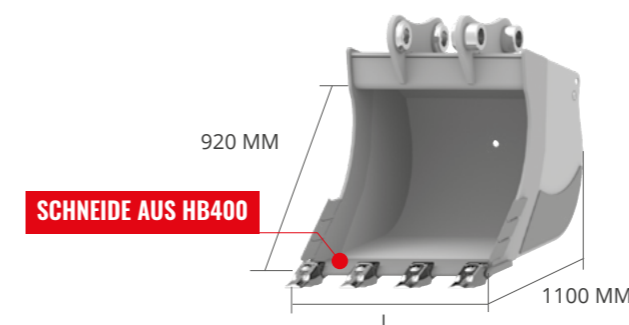

L MM	GEWICHT KG*	KAP. SAE L	ZÄHNE N°	ADAPTERS
600	261	380	4	AF - S - CM
				CS - CW
				CS JANUS PRO
700	287	450	4	AF - S - CM
				CS - CW
				CS JANUS PRO
800	320	560	5	AF - S - CM
				CS - CW
				CS JANUS PRO
900	352	620	5	AF - S - CM
				CS - CW
				CS JANUS PRO
1000	395	700	5	AF - S - CM
				CS - CW
				CS JANUS PRO
1200	454	900	6	AF - S - CM
				CS - CW
				CS JANUS PRO

\* Gewicht des Löffel ohne Anbauteile und Zähne

### ZUBEHÖR

5  
AUFSTECKMESSER

### ZUBEHÖR

5  
AUFSTECKMESSER

## SCR100 HD MASCHINENGEWICHT 14,0 - 16,0

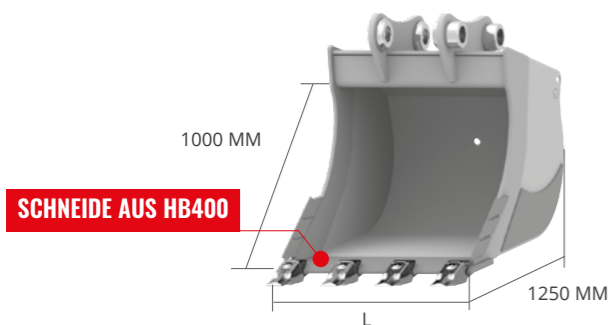

L MM	GEWICHT KG*	KAP. SAE L	ZÄHNE N°	ADAPTERS
600	353	450	3	AF - S - CM
				CS - CW
				CS JANUS PRO
700	397	535	4	AF - S - CM
				CS - CW
				CS JANUS PRO
800	441	620	4	AF - S - CM
				CS - CW
				CS JANUS PRO
900	485	710	4	AF - S - CM
				CS - CW
				CS JANUS PRO
1000	529	800	5	AF - S - CM
				CS - CW
				CS JANUS PRO
1200	617	980	5	AF - S - CM
				CS - CW
				CS JANUS PRO

\* Gewicht des Löffel ohne Anbauteile und Zähne

## SCR110 HD MASCHINENGEWICHT 16,0 - 18,0

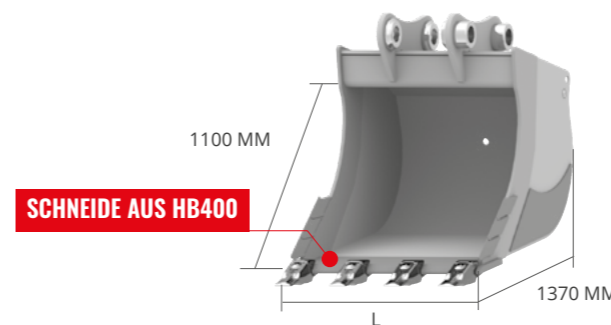

L MM	GEWICHT KG*	KAP. SAE L	ZÄHNE N°	ADAPTERS
600	457	480	3	AF - S - CM
				CS - CW
				CS JANUS PRO
800	559	690	4	AF - S - CM
				CS - CW
				CS JANUS PRO
1000	671	900	5	AF - S - CM
				CS - CW
				CS JANUS PRO
1200	773	1110	5	AF - S - CM
				CS - CW
				CS JANUS PRO
1300	824	1220	6	AF - S - CM
				CS - CW
				CS JANUS PRO
1400	875	1330	6	AF - S - CM
				CS - CW
				CS JANUS PRO

\* Gewicht des Löffel ohne Anbauteile und Zähne

### ZUBEHÖR

5  
AUFSTECKMESSER

### ZUBEHÖR

5  
AUFSTECKMESSER