



NEW

HB400



DER FELSLÖFFEL ZEICHNET SICH DURCH SEINE SCHMALE BAUWEISE MIT DEN SEHR TIEFEN SEITENWÄNDEN AUS. ER IST MIT VERSTÄRKUNGEN AUS HB 400 IN DEN HAUPTVERSCHLEISSSTELLEN.

| MOD. | MIDI EXCAVATOR | | | | | | | | | | | |
|------|----------------|-----------|-----------|-----------|-----------|-----------|-----------|------------|-------------|-------------|-------------|-------------|
| | BS 35HD | BS 40HD | BS 48HD | BS 60HD | BS 67HD | BS 71HD | BS 75HD | BS 80HD | BS 85HD | BS 92HD | BS 100HD | BS 110HD |
| TONS | 0,8 - 1,5 | 1,5 - 2,0 | 2,0 - 3,0 | 3,0 - 4,0 | 4,0 - 6,0 | 6,0 - 7,5 | 7,5 - 9,0 | 9,0 - 12,0 | 12,0 - 14,0 | 12,0 - 14,0 | 14,0 - 16,0 | 16,0 - 18,0 |



ADAPTERS

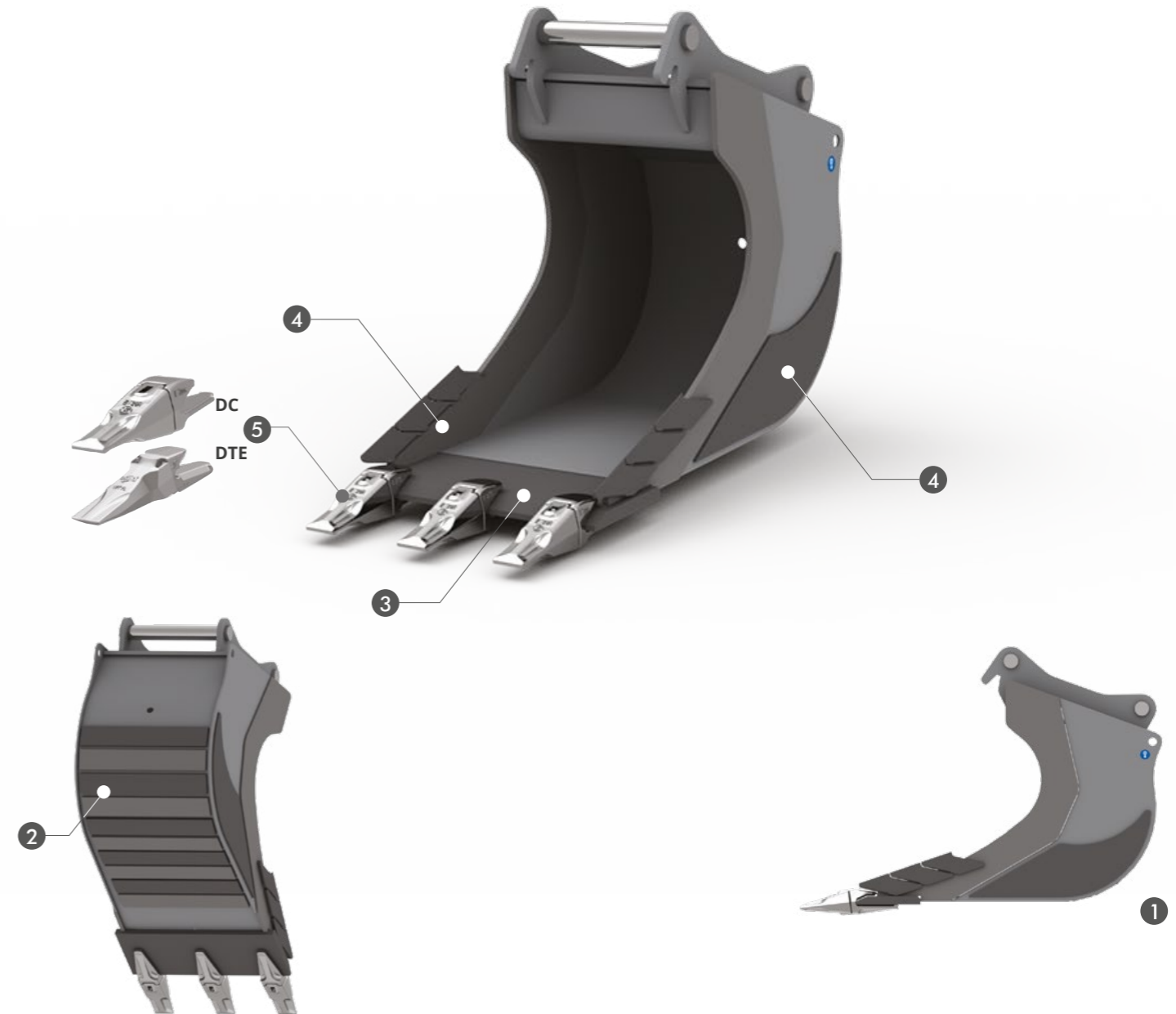

STANDARD TECHNISCHE DATEN

- 1 LANGGEZOGENES PROFIL DOPPELTE**
- 2 VERSTÄRKTER VERSCHLEISS-SCHUTZ HB400**
DIE WAAGERECHTEN VERSTÄRKUNGEN BIETEN OPTIMALEN VERSCHLEISSSCHUTZ UND SCHÜTZEN DIE STRUKTUR.
- 3 SCHNEIDE AUS HB400**
- 4 MESSER-SEITENSCHNEIDEN HB400 SEITENVERSTÄRKUNGEN**
DIE SEITENSCHNEIDEN SIND AUS HB 400. SIE SCHNEIDEN DAS MATERIAL BEIM ERDAUSHUB UND DIENEN ZUSÄTZLICH ALS VERSCHLEISSSCHUTZ.
- 5 ZÄHNE DC ZÄHNE DTE**

BS35 HD MASCHINENGEWICHT 0,8 - 1,5

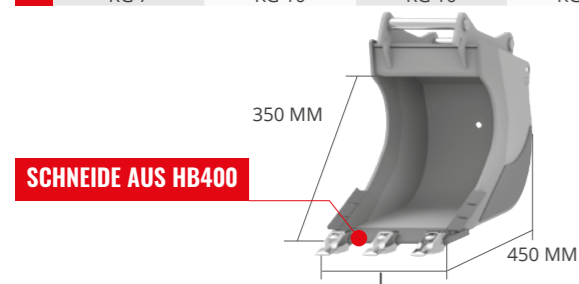

| L MM | GEWICHT KG* | KAP. SAE L | ZÄHNE N° | ADAPTERS |
|---------|----------------|---------------|-------------|-------------------|
| 250 | 22 | 24 | 3 | AF - AR - CS |
| | | | | CR - S - CM |
| | | | | CW - CS JANUS PRO |
| 300 | 24 | 29 | 3 | AF - AR - CS |
| | | | | CR - S - CM |
| | | | | CW - CS JANUS PRO |
| 350 | 27 | 35 | 3 | AF - AR - CS |
| | | | | CR - S - CM |
| | | | | CW - CS JANUS PRO |
| 400 | 31 | 41 | 3 | AF - AR - CS |
| | | | | CR - S - CM |
| | | | | CW - CS JANUS PRO |

BS48 HD MASCHINENGEWICHT 2,0 - 3,0

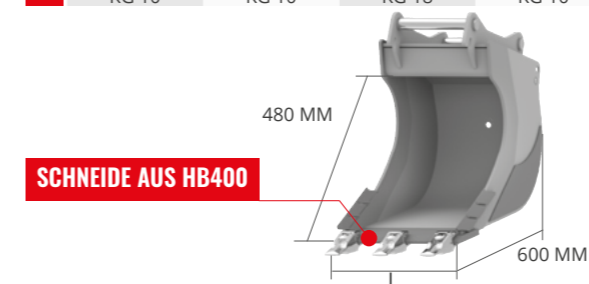

| L MM | GEWICHT KG* | KAP. SAE L | ZÄHNE N° | ADAPTERS |
|---------|----------------|---------------|-------------|-------------------|
| 250 | 37 | 36 | 3 | AF - AR - CS |
| | | | | CR - S - CM |
| | | | | CW - CS JANUS PRO |
| 300 | 42 | 45 | 3 | AF - AR - CS |
| | | | | CR - S - CM |
| | | | | CW - CS JANUS PRO |
| 350 | 47 | 54 | 3 | AF - AR - CS |
| | | | | CR - S - CM |
| | | | | CW - CS JANUS PRO |
| 400 | 53 | 63 | 3 | AF - AR - CS |
| | | | | CR - S - CM |
| | | | | CW - CS JANUS PRO |
| 500 | 64 | 83 | 4 | AF - AR - CS |
| | | | | CR - S - CM |
| | | | | CW - CS JANUS PRO |

BS40 HD MASCHINENGEWICHT 1,5 - 2,0

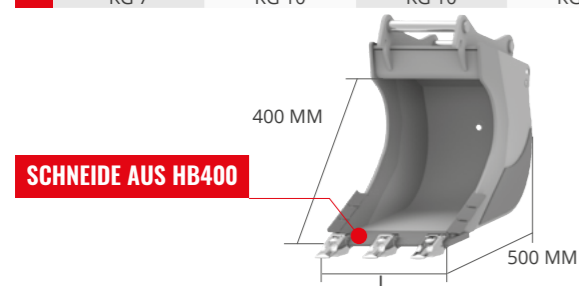

| L MM | GEWICHT KG* | KAP. SAE L | ZÄHNE N° | ADAPTERS |
|---------|----------------|---------------|-------------|-------------------|
| 250 | 25 | 24 | 3 | AF - AR - CS |
| | | | | CR - S - CM |
| | | | | CW - CS JANUS PRO |
| 300 | 27 | 30 | 3 | AF - AR - CS |
| | | | | CR - S - CM |
| | | | | CW - CS JANUS PRO |
| 350 | 30 | 37 | 3 | AF - AR - CS |
| | | | | CR - S - CM |
| | | | | CW - CS JANUS PRO |
| 400 | 34 | 44 | 3 | AF - AR - CS |
| | | | | CR - S - CM |
| | | | | CW - CS JANUS PRO |

BS60 HD MASCHINENGEWICHT 3,0 - 4,0

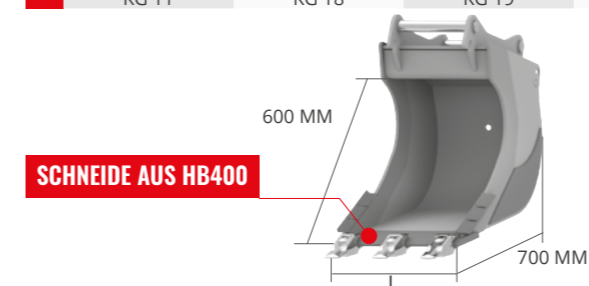

| L MM | GEWICHT KG* | KAP. SAE L | ZÄHNE N° | ADAPTERS |
|---------|----------------|---------------|-------------|-------------------|
| 250 | 48 | 54 | 3 | AF - AR - CS |
| | | | | CR - S - CM |
| | | | | CW - CS JANUS PRO |
| 300 | 53 | 66 | 3 | AF - AR - CS |
| | | | | CR - S - CM |
| | | | | CW - CS JANUS PRO |
| 350 | 60 | 79 | 3 | AF - AR - CS |
| | | | | CR - S - CM |
| | | | | CW - CS JANUS PRO |
| 400 | 66 | 93 | 3 | AF - AR - CS |
| | | | | CR - S - CM |
| | | | | CW - CS JANUS PRO |
| 500 | 78 | 121 | 4 | AF - AR - CS |
| | | | | CR - S - CM |
| | | | | CW - CS JANUS PRO |

* Gewicht des Löffel ohne Anbauteile und Zähne

* Gewicht des Löffel ohne Anbauteile und Zähne

BS67 HD MASCHINENGEWICHT 4,0 - 6,0

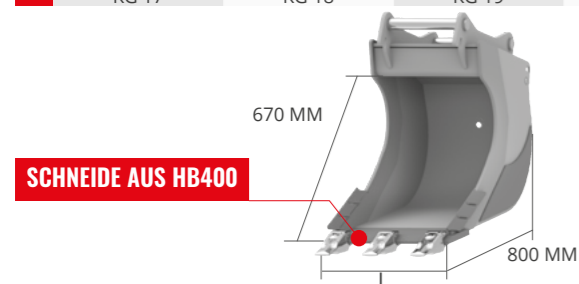

| L MM | GEWICHT KG* | KAP. SAE L | ZÄHNE N° | ADAPTERS |
|---------|----------------|---------------|-------------|-------------------|
| 300 | 70 | 78 | 3 | AF - AR - CS |
| | | | | CR - S - CM |
| | | | | CW - CS JANUS PRO |
| 350 | 80 | 95 | 3 | AF - AR - CS |
| | | | | CR - S - CM |
| | | | | CW - CS JANUS PRO |
| 400 | 90 | 111 | 3 | AF - AR - CS |
| | | | | CR - S - CM |
| | | | | CW - CS JANUS PRO |
| 500 | 109 | 146 | 4 | AF - AR - CS |
| | | | | CR - S - CM |
| | | | | CW - CS JANUS PRO |

BS75 HD MASCHINENGEWICHT 7,5 - 9,0

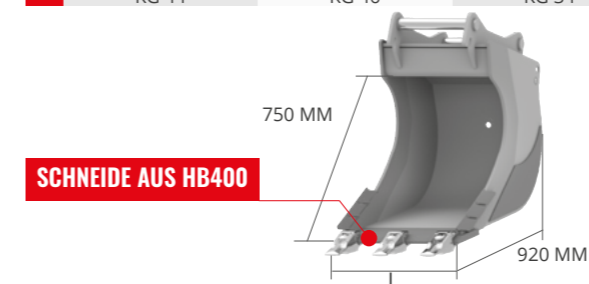

| L MM | GEWICHT KG* | KAP. SAE L | ZÄHNE N° | ADAPTERS |
|---------|----------------|---------------|-------------|-------------------|
| 350 | 106 | 117 | 3 | AF - CS |
| | | | | CR - S - CM |
| | | | | CW - CS JANUS PRO |
| 400 | 118 | 138 | 3 | AF - CS |
| | | | | CR - S - CM |
| | | | | CW - CS JANUS PRO |
| 500 | 138 | 181 | 3 | AF - CS |
| | | | | CR - S - CM |
| | | | | CW - CS JANUS PRO |
| 600 | 160 | 226 | 4 | AF - CS |
| | | | | CR - S - CM |
| | | | | CW - CS JANUS PRO |

BS71 HD MASCHINENGEWICHT 6,0 - 7,5

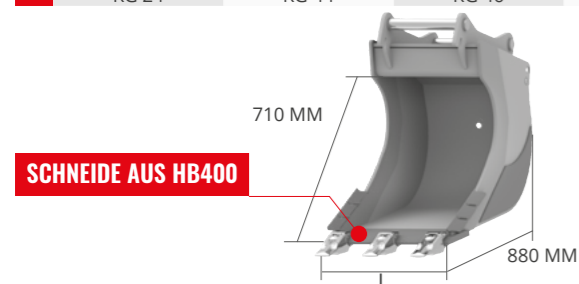

| L MM | GEWICHT KG* | KAP. SAE L | ZÄHNE N° | ADAPTERS |
|---------|----------------|---------------|-------------|-------------------|
| 350 | 101 | 112 | 3 | AF - AR - CS |
| | | | | CR - S - CM |
| | | | | CW - CS JANUS PRO |
| 400 | 111 | 132 | 3 | AF - AR - CS |
| | | | | CR - S - CM |
| | | | | CW - CS JANUS PRO |
| 500 | 133 | 172 | 3 | AF - AR - CS |
| | | | | CR - S - CM |
| | | | | CW - CS JANUS PRO |
| 600 | 152 | 215 | 4 | AF - AR - CS |
| | | | | CR - S - CM |
| | | | | CW - CS JANUS PRO |

BS80 HD MASCHINENGEWICHT 9,0 - 12,0

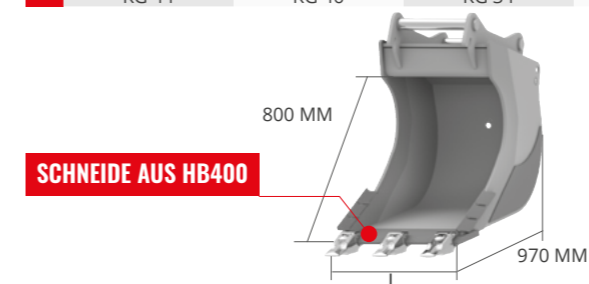

| L MM | GEWICHT KG* | KAP. SAE L | ZÄHNE N° | ADAPTERS |
|---------|----------------|---------------|-------------|-------------------|
| 400 | 130 | 161 | 3 | AF - CS |
| | | | | CR - S - CM |
| | | | | CW - CS JANUS PRO |
| 500 | 157 | 210 | 3 | AF - CS |
| | | | | CR - S - CM |
| | | | | CW - CS JANUS PRO |
| 600 | 186 | 261 | 3 | AF - CS |
| | | | | CR - S - CM |
| | | | | CW - CS JANUS PRO |

* Gewicht des Löffel ohne Anbauteile und Zähne

* Gewicht des Löffel ohne Anbauteile und Zähne

BS85 HD MIDI MASCHINENGEWICHT 12,0 - 14,0

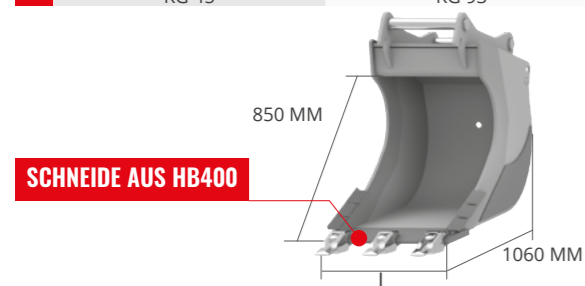

| L MM | GEWICHT KG* | KAP. SAE L | ZÄHNE N° | ADAPTERS |
|---------|----------------|---------------|-------------|--------------|
| 400 | 164 | 184 | 3 | AF - S - CM |
| | | | | CS - CW |
| | | | | CS JANUS PRO |
| 500 | 192 | 242 | 3 | AF - S - CM |
| | | | | CS - CW |
| | | | | CS JANUS PRO |
| 600 | 220 | 301 | 4 | AF - S - CM |
| | | | | CS - CW |
| | | | | CS JANUS PRO |

BS100 HD MASCHINENGEWICHT 14,0 - 16,0

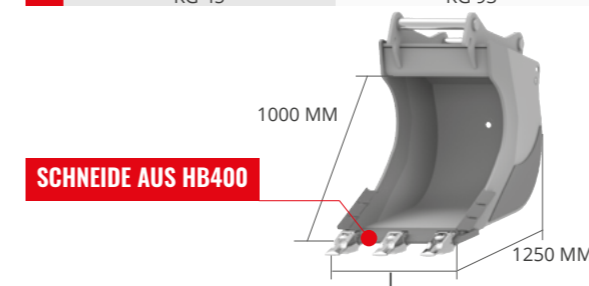

| L MM | GEWICHT KG* | KAP. SAE L | ZÄHNE N° | ADAPTERS |
|---------|----------------|---------------|-------------|--------------|
| 400 | 259 | 245 | 3 | AF - S - CM |
| | | | | CS - CW |
| | | | | CS JANUS PRO |
| 500 | 301 | 320 | 3 | AF - S - CM |
| | | | | CS - CW |
| | | | | CS JANUS PRO |
| 600 | 343 | 398 | 3 | AF - S - CM |
| | | | | CS - CW |
| | | | | CS JANUS PRO |

BS92 HD EXCAVATOR MASCHINENGEWICHT 12,0 - 14,0

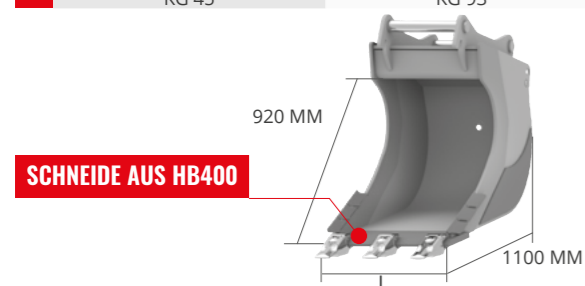

| L MM | GEWICHT KG* | KAP. SAE L | ZÄHNE N° | ADAPTERS |
|---------|----------------|---------------|-------------|--------------|
| 400 | 188 | 206 | 3 | AF - S - CM |
| | | | | CS - CW |
| | | | | CS JANUS PRO |
| 500 | 225 | 270 | 3 | AF - S - CM |
| | | | | CS - CW |
| | | | | CS JANUS PRO |
| 600 | 256 | 337 | 4 | AF - S - CM |
| | | | | CS - CW |
| | | | | CS JANUS PRO |

BS110 HD MASCHINENGEWICHT 16,0 - 18,0

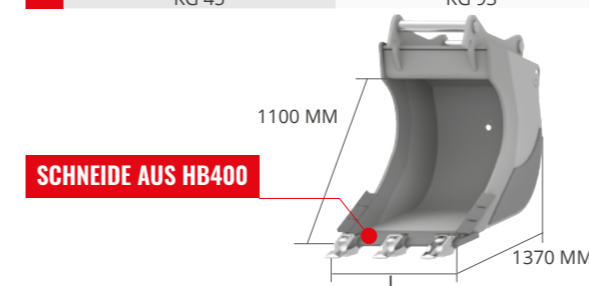

| L MM | GEWICHT KG* | KAP. SAE L | ZÄHNE N° | ADAPTERS |
|---------|----------------|---------------|-------------|--------------|
| 400 | 335 | 243 | 3 | AF - S - CM |
| | | | | CS - CW |
| | | | | CS JANUS PRO |
| 500 | 385 | 372 | 3 | AF - S - CM |
| | | | | CS - CW |
| | | | | CS JANUS PRO |
| 600 | 435 | 464 | 3 | AF - S - CM |
| | | | | CS - CW |
| | | | | CS JANUS PRO |

* Gewicht des Löffel ohne Anbauteile und Zähne

* Gewicht des Löffel ohne Anbauteile und Zähne